

GRAPES DRAYING YARD

Name Of Work :-Proposed Construction of Grapes Draying Yard Unit For BBP Baeshi Taluka Agro Processing & Agro Producer Co.ltd, In Gat no.210/1, At-Raleras ,Tq-Barshi, Dist-Solapur (MH)

Director : Shri. Prakash Ramchandra Kaluke.

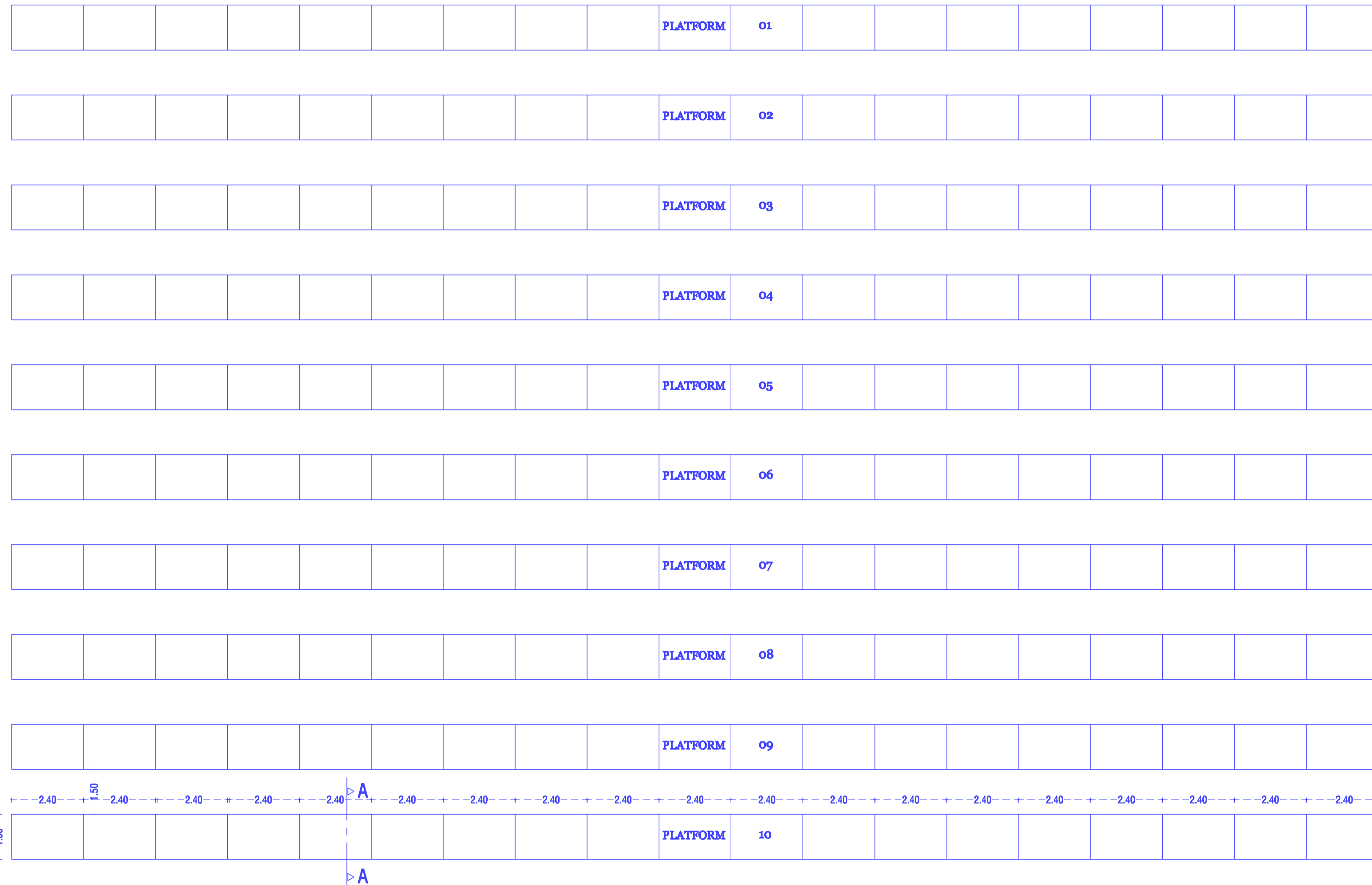

GRAPES DRAYING YARD PLAN



BLOCK PLAN (A)

BLOCK PLAN

BUILT UP AREA CALCULATION

SHED SIZE	PROPOSED	SQ.MT.
MAIN SHED :	(A)	
45.73 M X 1.50 M	=	68.59 SQ.MT.
68.59 SQ.MT. X 10 NO.	=	685.90 SQ.MT.
TOTAL AREA =		685.90 SQ.MT.

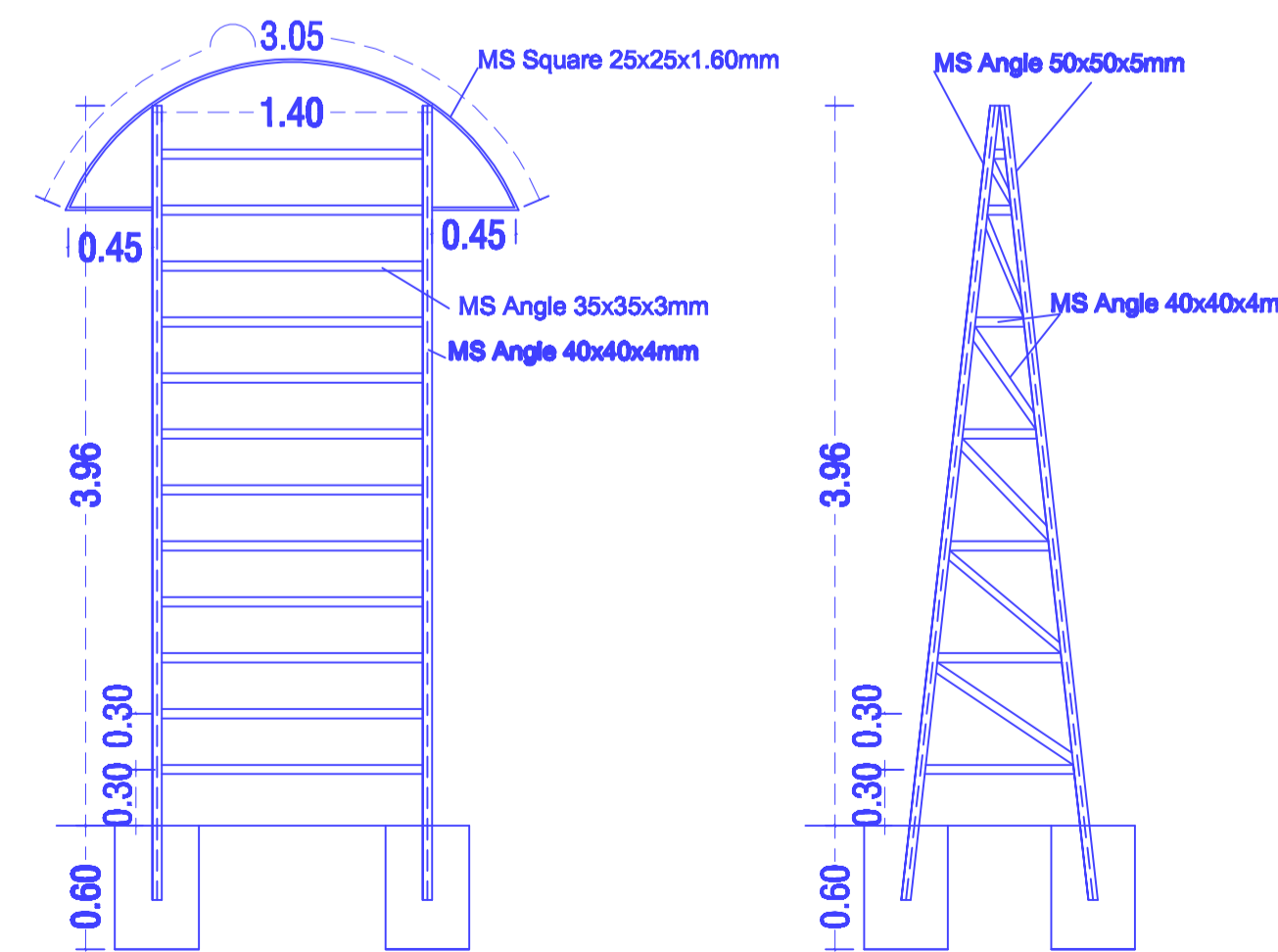

SECTION-AA CROSS SECTION-AA

Owner's declaration

I/We undersigned hereby confirm that I/we would abide by plans.I/We would execute the structure as per sanctioned plans.Also I/We would execute the work under supervision of proper technical person so as to ensure the quality and safety at the work site

owner [S] name and signature FOR: Director : Shri. Prakash Ramchandra Kaluke.

Architect/Licensed Engineer/Supervisor name and signature

Rajendra Bhaskar
Gaurav Rajendra Bhaskar
 B.E.(Civil) A.M.I.E.
 Chartered Engineer
 AM3023322
 Chartered Engineer

Prakash
SAI CONSULTANT'S
 Consulting Civil Engineer
 Rahuri, Dist. Ahmednagar
 Registration/ License no of
 Arch./Lic.Eng./Supervisor



SAI CONSULTANT'S

CONSULTING CIVIL ENGINEERS & CONTRACTORS.
 RAHURI
 L.C.NO.ADTP-A/C-5/111.
 MO.9970253888,9881964333.